



StarPoint

8° version

Order code: 10700

CONTENTS

1	PICTURE	3
1.1	GENERAL	3
2	DIMENSIONS	4
3	SAFETY INFORMATION	5
3.1	SYMBOLS	5
3.2	PROTECTION FROM ELECTRIC SHOCK	6
3.3	PROTECTIONS FROM FIRE AND BURNS	6
3.4	PROTECTION FROM INJURY	7
3.5	DISPOSING OF THIS PRODUCT	7
4	PHYSICAL INSTALLATION	8
4.1	UNPACKING	8
4.2	MOUNTING	8
4.3	LOCATION AND ORIENTATION	8
5	EXTERNAL CONNECTIONS	9
5.1	DC POWER INPUT	9
6	EMC AND SAFETY REQUIREMENTS	10
7	INSTALLATION SETUP	11
7.1	SPECIFICATION	11
8	SERVICE AND MAINTENANCE	12
8.1	SAFETY PRECAUTIONS	12
8.2	CLEANING	12
9	WARRANTY	13
9.1	APPLICATION OF WARRANTY	13
9.2	RMA PROCEDURE	15
10	LIST OF USED ABBREVIATIONS	16

Picture

1.1 General



StarPoint 8° on bracket



StarPoint 8° with snoot

2

Dimensions

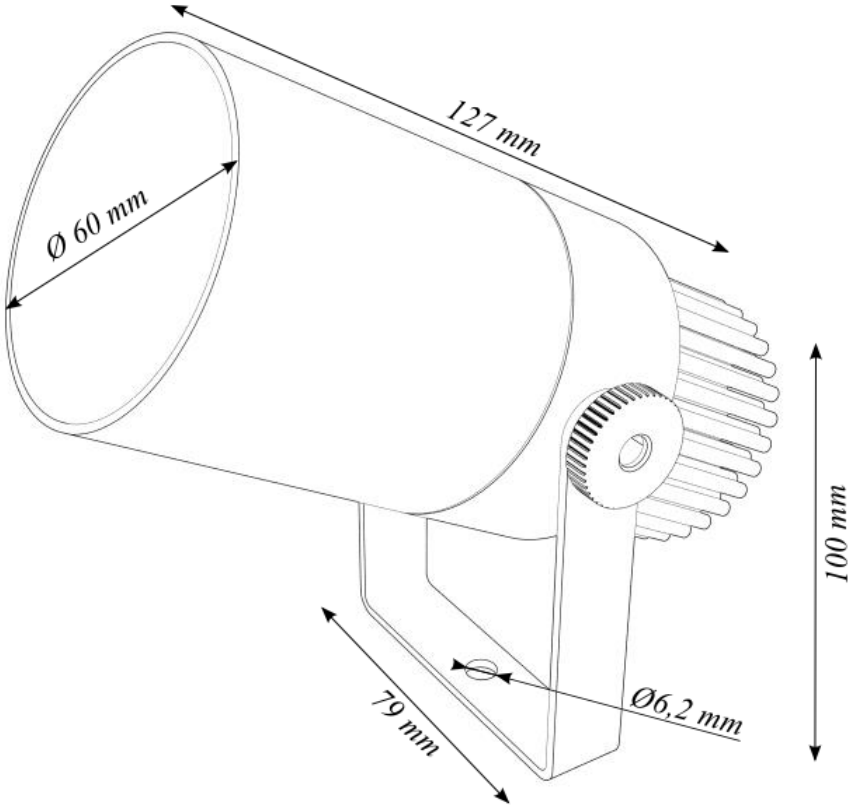

Safety information

Before installing, powering up, or servicing the StarPoint led-unit, it is highly recommended that you read this manual and ensure yourself that you completely understand its content. Observe the safety precautions in this manual. Install and operate the led-unit only as described in this manual, and in conformity with local regulations. If you have any questions how to operate this product safely, please contact your point of sale.

3.1 Symbols

Following symbols are used to identify important safety information on the product and in this manual.



DANGER!
Safety hazard. Risk of severe injury or death.



Warning!
Hazardous voltage. Risk of lethal or severe electric shock.



Warning!
LED light emission. Risk of eye injury.



Warning!
Burn hazard. Hot surface. Do not touch



Warning!
Refer to user manual.

3.2 Protection from electric shock



Although this device itself does not operate with dangerous voltages, the installation in which is intended to be used, can contain dangerous voltages.

Shut down the power of the complete installation before carrying out any installation, or maintenance work.

Use only AC to DC power sources, suitable for the application, and conform to local regulations. Please ensure yourself that the AC to DC power supply is able to deliver the rated current requirements of the installation.

If any cable, seal or housing is damaged, cracked, or reformed, disconnect the power of the installation immediately.

For any additional servicing, not described in this manual, please contact your point of sale.

3.3 Protections from fire and burns



Do not operate this led-unit if ambient temperature is over 45 °C (113 °F). Please ensure yourself that sufficient ventilation around the led-unit is possible.

It might be necessary to allow the led-unit to cool down for 5 minutes, before servicing.

Do not modify the led fixture, in a way, not described in this manual.

3.4 Protection from injury



Ensure yourself that the led-unit and all its accessories are securely fastened. Verify that the led-unit is firmly fixed to its supporting underground.

3.5 Disposing of this product



This led-lighting device is manufactured in compliance with directive of the European community: waste electrical and electronically equipment. Please help to preserve our environment and ensure that this product will be recycled properly at the end of its life.



Physical installation

Thank you for selecting this StarPoint 8° led-unit as best solution in your setup.

Warning! Read the safety precautions in this manual before integrating this led-unit into your installation.

Installation must be carried out by qualified professionals only.

Assure yourself that there is sufficient and unrestricted air flow around the StarPoint led-unit.

4.1 Unpacking

The following items are included in your package:

- led fixture with focussing bracket and snoot included
- Protective antistatic packaging, with short form manual

4.2 Mounting

Surface mounting

The StarPoint led-unit can be mounted on all kind of non combustible materials but take in consideration that the module can have a Tc of approx 30 °C higher as ambient temperature.

In case of problems, or doubts, please contact your point of sale.

Track mounting (on demand)

The StarPoint led-unit can be equipped with a track adaptor in order to be installed easily on 24 VDC track systems.

4.3 Location and orientation

This led-unit can be used in all directions.

External connections

5.1 DC power input

Safety precautions

Never connect the live power on the input terminals of the StarPoint led-unit!

In case of doubts, contact your point of sale.

Polarity

The StarPoint led-unit is polarity sensitive. So observe polarity and cabling:

- Black inner 1 = positive
- Black inner 2 = negative

Improper connection might damage the StarPoint led-unit and power supply permanently. In case of inversed polarity, the warranty is void.

Power supply: Rated voltage

The rated input voltage range of the StarPoint led-unit is 24 VDC. Due to the use of a step down-convertor, integrated in the housing, a highly efficient system is created.

Cable

Please ensure yourself that the cable end is watertight sealed at the connection. If this is not properly done, water can pass through the inner conductors of the cable and damage the internal electronics of the StarPoint led-unit.



EMC and safety requirements

The StarPoint led-unit is fully compliant to the LVD and EMC directive of the European council, if used in a properly designed setup.

The StarPoint led-unit is only intended to be used in lighting applications, and as such, the complete assembly of led-unit and power supply needs to be fully compliant with following harmonized standards:

LVD requirements of the power supply

- EN 60598: general requirements of lighting equipment.

EMC requirements of the power supply

Immunity according to:

- EN 61547:2009 (General EMC immunity requirements lighting eq.)
- EN 61000-4-1:2006 (General immunity testing techniques)
- EN 61000-4-2:2008 (ESD immunity test)
- EN 61000-4-3:2006 + A1:2007 (Radiated immunity test)
- EN 61000-4-4:2004 (Fast transients and burst immunity)
- EN 61000-4-5:2005 (Surge immunity test)
- EN 61000-4-6:2008 (Conducted immunity test)
- EN 61000-4-8:1993 (Magnetic field immunity test)
- EN 61000-4-11:2004 (Voltage variations immunity test)
- EN 61000-6-1:2005 (Generic standards for immunity)

Emission according to:

- EN 61000-3-2:2005+A1:2008+A2:2009 (Harmonics emission test<16A)
- EN 61000-3-3:2008 (Flicker+ voltage changes limits< 16A)
- EN 55015:2006+A2:2009 (Conducted + radiated emission lighting equipment)

To achieve this compliance, a proper power supply must be supplied. In case of doubts, contact your point of sale.

Installation setup

7.1 Specification

The StarPoint led-unit has a very narrow light beam. It is an ideal solution to accentuate details from a large distance.

The ingress protection of this StarPoint led-unit is IP67, and as such, the unit can be used in outdoor as well as indoor applications.

The housing is made out of anodized aluminium in black finish. RAL colors are not available.

It uses a simple stabilized 24VDC power supply.

- Power consumption: 8W
- Voltage: 24VDC
- Weight: 350gr

The StarPoint led-unit has a very narrow light beam of 8°. The StarPoint comes standard with snoot to prevent light glare.

- Different white light colors are possible:
 - Warm white: 2700K, CRI80
 - Neutral white: 4000K, CRI80
- Other light colors or CRI values on demand, with longer delivery time.

Service and maintenance

8.1 Safety precautions



Read carefully the safety information in this manual. Lock out the power on the entire system and allow all electronic devices to discharge, and cool down, before executing any service or maintenance.

8.2 Cleaning

The StarPoint led-unit itself



Extensive dirt, and particle build-up degrades performance, may cause overheating can result in damaged led-unit and power supplies. Damage by inadequate cleaning or maintenance is not covered by the product warranty.

Never use solvents to clean the outer housing of the unit.

Never use water, or wet cloth.

Warranty

9.1 Application of warranty

Warranty period

Warranty service is valid for one year from the date of purchase by the consumer, as evidenced by invoice date given out by your point of sale.

Warranty service

Service under warranty can only be done by Lux Lumen.

Coordinates:

Lux Lumen
Kernenergiestraat 53 A
2610 Wilrijk
Belgium

Any cost of secure transportation of the product to and from Lux Lumen service department, will be borne by the customer.

Limitations

Lux Lumen will not warrant the following:

- Periodic check-ups, maintenance and repair or replacement of parts due to normal wear and tear.
- Consumables
- Any software
- Defects caused by modifications carried out without Lux Lumen's approval.
- Damage resulting from the fact that a product is not conforming to country specific standards or specifications in another country than the country of purchase.

Costs incurred by Lux Lumen's service center in making any adoptions or modifications of a product necessary for country specific technical or safety standards or specifications, or any other cost to adjust the product as a result of any specifications which have changed since the delivery of the product.

Warranty service is excluded if damage or defects have been caused by:

Improper use, extensive use, handling or operation of the product as referred to in the user manual or operator manual and/or relevant user documents, including without limitation, incorrect storage, dropping, excessive shocks, corrosions, dirt, water, or sand damage, if the product is not rated to be used in severe conditions, indicated by its IP and IK degree, mentioned in the product specifications in this manual.

Repairs, modifications or cleaning carried out by a non Lux Lumen service centre.

Use of spare parts, software or consumables, which are not compatible with the product.

Connecting the product to equipment not intended to be used with this product.

Defects caused by improper condition of the power supply network.

Inadequate packaging of the product when returning it under the RMA procedure.

Accidents or disasters or any cause beyond the control of Lux Lumen, including but not limited to lightning, water, fire, public disturbances, improper ventilation, and acts of God.

Others

It is the responsibility of the customer to backup and save any software files and programs before repair and to restore the same after such repair.

This warranty does not affect the consumer's statutory rights under applicable national legislation in force, nor the consumer's rights against the retailer arising from the sales/purchase contract. In the absence of applicable national legislation, this warranty will be the consumer's sole and exclusive remedy, and Lux Lumen cannot be liable for any incidental or consequential damages for breach of any express or implied warranty of this product.

For full details of the warranty offered on this product, please contact Lux Lumen's service center.

9.2 RMA procedure

To send material back to Lux Lumen, you need a RMA (Return Material Authorization) document that you will receive from Lux Lumen.

Without the RMA document, we cannot accept the material.

The procedure to obtain a RMA:

Step 1:

Customer contacts Lux Lumen about warranty, defects if material has to be returned.

Step 2:

Lux Lumen sends the customer a filled out RMA document (using a unique RMA number)

Step 3:

Customer sends material (include a copy of the RMA document with the material)

Step 4:

Lux Lumen evaluates the problem, and informs the client if repair is done under warranty or makes an offer to the client for repair.

List of used abbreviations

- AC: Alternating current
- DC: Direct current
- °F: Temperature in degrees Fahrenheit
- °C: Temperature in degrees Celsius
- LED: Light Emitting Diode
- CRI: Color Rendering Index
- RMA: Return Material Authorization
- LVD: Low Voltage Directive
- EMC: ElectroMagnetic Compatibility