

iW COVE POWERCORE

An IntelliWhite™ Product



The iW™ Cove Powercore fixture combines the intelligent white LED illumination systems of the IntelliWhite™ family with the versatile housing of the iColor Cove® MX fixture. This high performance 12" (30.2 cm) linear fixture is designed for common interior alcove applications, such as lobbies, atriums, schools, museums, malls, or other public spaces. Integrated Powercore® technology provides greater operational efficiency and simplified installation.

Powercore technology, a digital power processing technology that drives LED systems, integrates power and data management directly into the fixture and eliminates the need for an external power supply. Powercore surpasses traditional power supply technology by streamlining multiple conversion and regulation stages into a single, flexible, microprocessor-controlled power stage that controls power output to LED systems directly from line voltage and significantly increases overall system efficiency.

iW Cove Powercore is available in medium and asymmetric beam angles. The asymmetric version provides a true forward-throw asymmetric projection of light. This option is designed to deliver superior surface uniformity with no waste, resulting in a better ratio of light projected onto the receiving surface with an even distribution from top to bottom when used in alcove applications.

iW Cove Powercore's integral, two-point mounting bracket simplifies installation. It permits 180° of rotation, with detents every 10°. This provides adjustable aiming to tailor the illumination performance to the application. The fixture can be rotated to the desired position and locked in place with the included set screws. The end-to-end locking connectors, capable of making 180° turns, make iW Cove Powercore extremely versatile and easily adaptable to even the most challenging mounting requirements. An optional mounting track is available for linear runs.

iW Cove Powercore receives data via Color Kinetics® iW Data Enabler – a data formatting device specifically designed for use with Color Kinetics IntelliWhite Powercore based fixtures and line of iW controllers. Each iW Data Enabler will support up to 48 (110VAC), 74 (220VAC), or 78 (240VAC) iW Cove Powercore fixtures, using a 40-foot (12 m) field-cutable leader cable. One-foot (0.3 m) and five-foot (1.5 m) jumper cables are available for installations that require spacing between fixtures.

iW COVE POWERCORE SPECIFICATIONS

COLOR TEMP RANGE	3000K to 6500K adjustable
SOURCE	High intensity LEDs
BEAM ANGLE	Medium (50° x 50°), Forward-Throw Asymmetric (20° x 30° x 160°)
HOUSING	Die cast aluminum, powder coated 12.00" x 2.00" x 1.54" (30.48 cm x 5.09 cm x 3.90 cm)

CONNECTORS Integral male/female connectors

LISTINGS UL/cUL, CE

COMMUNICATION SPECIFICATIONS

DATA INTERFACE	Color Kinetics iW Data Enabler
CONTROL	Color Kinetics full line of controllers including iW Scene Controller or Light System Manager**

ELECTRICAL SPECIFICATIONS

POWER REQUIREMENT	100-240VAC, 50-60 Hz
POWER CONSUMPTION	15W
POWER FACTOR	0.95 or greater at 120VAC

ENVIRONMENTAL SPECIFICATIONS

TEMPERATURE RANGE -4°F to 122°F (-20°C to 50°C) based on testing of specific product

PROTECTION RATING IP50

** For large or complex installations, consider controlling iW Cove Powercore with Light System Manager (LSM). Refer to the LSM data sheets or contact support@colorkinetics.com for more information.

LED SOURCE LIFE

In traditional lamp sources, lifetime is defined as the point at which 50% of the lamps fail. This is also termed Mean Time Between Failure [MTBF]. LEDs are semiconductor devices and have a much longer MTBF than conventional sources. However, MTBF is not the only consideration in determining useful life. Color Kinetics uses the concept of useful light output for rating source lifetimes. Like traditional sources, LED output degrades over time (lumen depreciation) and this is the metric for SSL lifetime.

LED lumen depreciation is affected by numerous environmental conditions such as ambient temperature, humidity, and ventilation. Lumen depreciation is also affected by means of control, thermal management, current levels, and a host of other electrical design considerations. Color Kinetics systems are expertly engineered to optimize LED life when used under normal operating conditions. Lumen depreciation information is based on LED manufacturers' source life data as well as other third party testing. Low temperatures and controlled effects have a beneficial effect on lumen depreciation. Overall system lifetime could vary substantially based on usage and the environment in which the system is installed.

Temperature and effects will affect lifetime. Color Kinetics rates product lifetime using lumen depreciation to 70% of original light output. When the fixture is running on warm or cool, at room temperature, the LED lifetime is in the range 50,000 – 70,000 hours. This is based on LED manufacturers' test data. High output is defined as any LED device that is 1/2 watt or above. For more detailed information on source life, please see www.colorkinetics.com/lifetime.

CHROMACORE™
BY COLOR KINETICS

POWERCORE™
BY COLOR KINETICS

OPTIBIN™
BY COLOR KINETICS

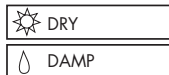

ITEM# 523-000002-00 (Medium)
ITEM # 523-000002-01 (Asymmetric)

This product is protected by one or more of the following patents: U.S. Patent Nos. 6,016,038, 6,150,774 and other patents listed at <http://colorkinetics.com/patents/>. Other patents pending.

©2005-2006 Color Kinetics Incorporated. All rights reserved. Chromacore, Chromatic, CK, the CK logo, Color Kinetics, the Color Kinetics logo, Color Kinetics The Leader in Intelligent Light, ColorBlast, ColorBlaze, ColorBurst, ColorCast, ColorPlay, ColorScape, DiMand, Direct Light, EssentialWhite, eW, iColor, iColor Cove, IntelliWhite, iW, iPlayer, Light Without Limits, Optibin, Powercore, QuickPlay, Sauce, the Sauce logo, and Smartjuice are either registered trademarks or trademarks of Color Kinetics Incorporated in the United States and/or other countries.

All other brand or product names are trademarks or registered trademarks of their respective owners.

BRO186 Rev 04

Specifications subject to change without notice. Refer to www.colorkinetics.com for the most recent data sheet versions.

iW COVE POWERCORE - MEDIUM

PHOTOMETRIC PERFORMANCE

SOURCE SPECIFICATIONS

Lens:	UV-resistant soft-focus polycarbonate lens
Source:	10 LEDs (5 warm white, 5 cool white)
Beam Angle:	50° X 50° (at 50% of peak illuminance)
Distribution:	Symmetric direct illumination
CCT:	Adjustable 3000–6500K
CRI:	81 All, 73 Warm, 86 Cool

ILLUMINANCE DISTRIBUTION

0.2 2.2	0.3 3.2	0.4 4.3	0.3 3.2	0.2 2.2	0.2 2.2	1.0'/0.3m
0.3 3.2	3.9 42.0	7.4 79.7	4.0 43.1	0.4 4.3	0.2 2.2	2.0'/0.6m
0.3 3.2	7.4 79.7	17.8 191.6	14.4 155.0	4.0 43.1	0.3 3.2	3.0'/1.0m
0.3 3.2	4.0 43.1	14.4 155.0	17.8 191.6	7.4 79.7	0.3 3.2	4.0'/1.2m
0.2 2.2	0.4 4.3	4.0 43.1	7.4 79.7	3.9 42.0	0.3 3.2	5.0'/1.5m
0.2 2.2	0.2 2.2	0.3 3.2	0.4 4.3	0.3 3.2	0.3 3.2	6.0'/2.0m
3.0'/1.0m		0'/0m		3.0'/1.0m		

Units: Footcandles (top)/Lux (bottom)
 10.8 lux = 1 fc
 Location: Centered 1'/0.3m from, and perpendicular to, surface
 Measured on: All, Reflectance 50%

ILLUMINANCE

	3' 1m	6' 2m	9' 3m	15' 5m
ALL	19.3 207.7	4.2 45.2	1.8 19.4	0.6 6.5

Measured in Footcandles (top)/Lux (bottom) on axis.
 Measured on all, reflectance 0.

CRI

It is common practice in the lighting industry to use color rendering index (CRI) to compare the properties of various light sources. There are known deficiencies and limitations associated with CRI and as a result, it is not always an accurate indicator of good object color appearance. This is especially true for LED-based sources. Until a better method for measuring color rendering in LEDs is accepted, Color Kinetics measures CRI in accordance with the current CIE 13.3-1995 standard using the Ra calculation. The reference illuminants employed are the Planckian locus below 5000K and CIE Daylight reference above 5000K. All measurements for Color Kinetics products are performed by third party laboratories using NIST-traceable instruments.

CANDLE POWER DISTRIBUTION

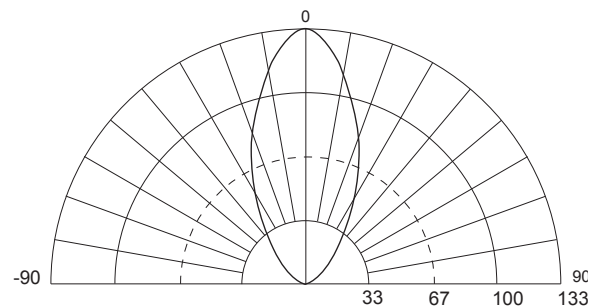

Measured on: All
 Beam peak: 133 cd
 Thin dashed line: Indicates 50% of peak

LIGHT OUTPUT

	TOTAL OUTPUT (lumens)	POWER (Watts)	EFFICACY (lm/W)
ALL	120	15.0	8.0
WARM	109	15.0	7.3
COOL	116	15.0	7.7

Note: Efficacy figures are for a complete tested fixture not simply a lamp source.

iW COVE POWERCORE - ASYMMETRIC

PHOTOMETRIC PERFORMANCE

SOURCE SPECIFICATIONS

Lens:	UV-resistant soft-focus polycarbonate lens
Source:	10 LEDs (5 warm white, 5 cool white)
Beam Angle:	20° x 30° x 160° (at 50% of peak illuminance)
Distribution:	Asymmetric direct illumination
CCT:	Adjustable 3000–6500K
CRI:	84 All, 78 Warm, 87 Cool

ILLUMINANCE DISTRIBUTION

0.7 7.5	0.9 9.7	0.9 9.7	0.9 9.7	0.8 8.6	0.6 6.5	6'/2m
1.1 11.8	1.7 18.3	1.8 19.4	1.7 18.3	1.4 15.1	0.9 9.7	
1.6 17.2	3.1 33.4	3.9 42.0	3.5 37.7	2.4 25.8	1.3 14.0	3'/1m
1.7 18.3	4.1 44.1	6.0 64.6	5.5 59.2	3.5 37.7	1.7 18.3	
1.4 15.1	3.6 38.8	6.0 64.6	6.0 64.6	3.8 40.9	1.6 17.2	0'/0m
1.1 11.8	2.7 29.1	4.8 51.7	5.0 53.8	3.0 32.3	1.2 12.9	
3'/1.0m		0'/0m		3'/1.0m		

Units: Footcandles (top)/Lux (bottom)
 10.8 lux = 1 fc
 Location: 2'/0.6m from surface, 45° tilt up from surface
 Measured on: Reflectance model 50/50/50

ILLUMINANCE

	0.5' 0.15m	1' 0.3m	2' 0.6m	3' 1m
ALL	4544.0 48911.6	182.0 1959.0	26.9 289.6	10.3 110.9

Measured in Footcandles (top)/Lux (bottom).
 Measured on: Reflectance 0.

CRI

It is common practice in the lighting industry to use color rendering index (CRI) to compare the properties of various light sources. There are known deficiencies and limitations associated with CRI and as a result, it is not always an accurate indicator of good object color appearance. This is especially true for LED-based sources. Until a better method for measuring color rendering in LEDs is accepted, Color Kinetics measures CRI in accordance with the current CIE 13.3-1995 standard using the Ra calculation. The reference illuminants employed are the Planckian locus below 5000K and CIE Daylight reference above 5000K. All measurements for Color Kinetics products are performed by third party laboratories using NIST-traceable instruments.

CANDLE POWER DISTRIBUTION

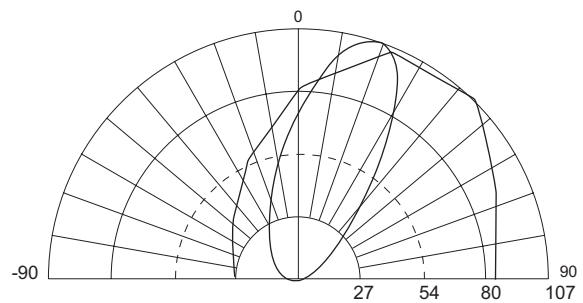

Measured on: All
 Beam peak: 107 cd
 Thin dashed line: Indicates 50% of peak

LIGHT OUTPUT

	TOTAL OUTPUT (lumens)	POWER (Watts)	EFFICACY (lm/W)
ALL	116	15	7.7
WARM	97	15	6.5
COOL	119	15	7.9

Note: Efficacy figures are for a complete tested fixture not simply a lamp source.

iW COVE POWERCORE

PHYSICAL DIMENSIONS

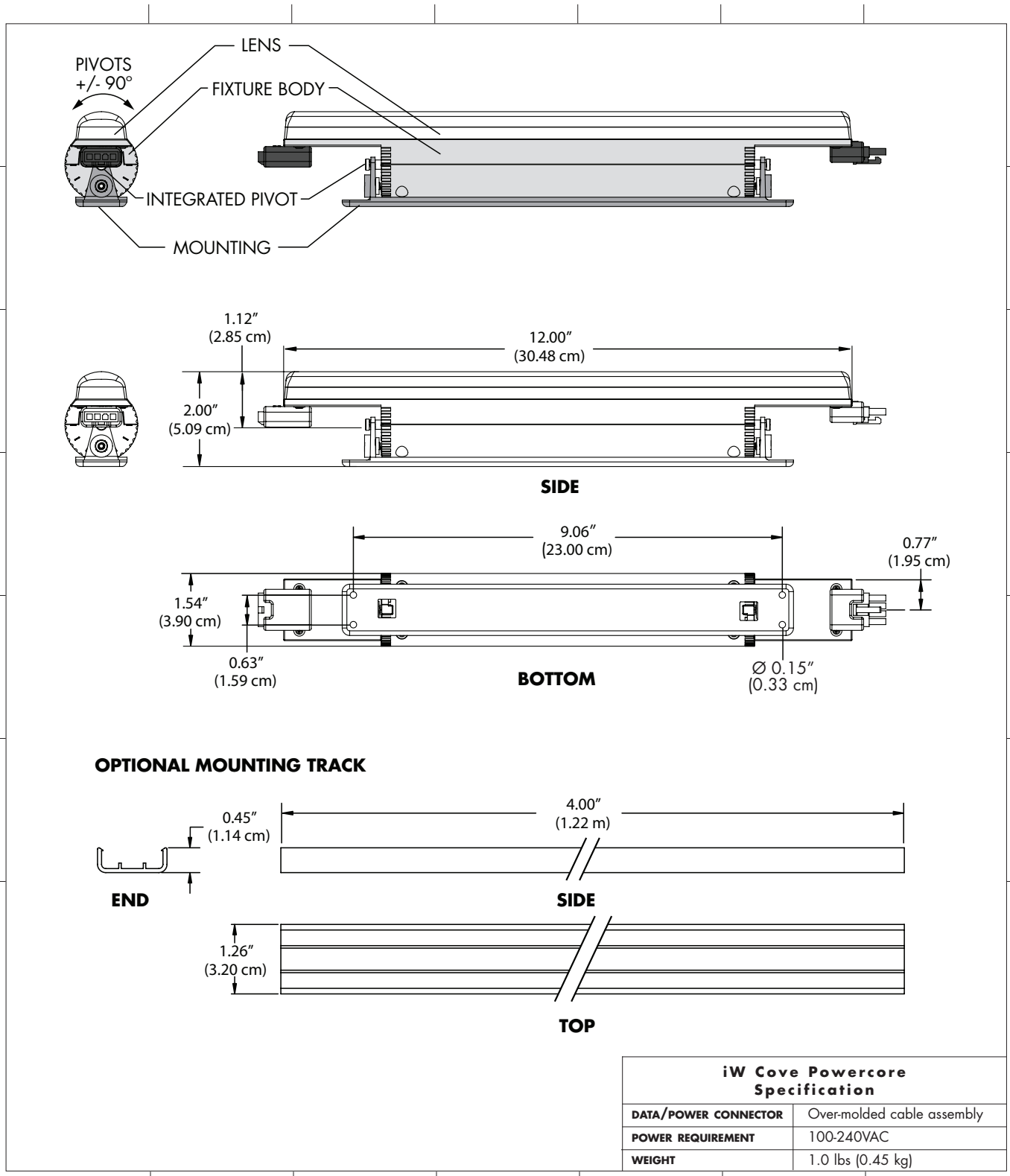

iW COVE POWERCORE

FUNCTIONAL FLOW DIAGRAM

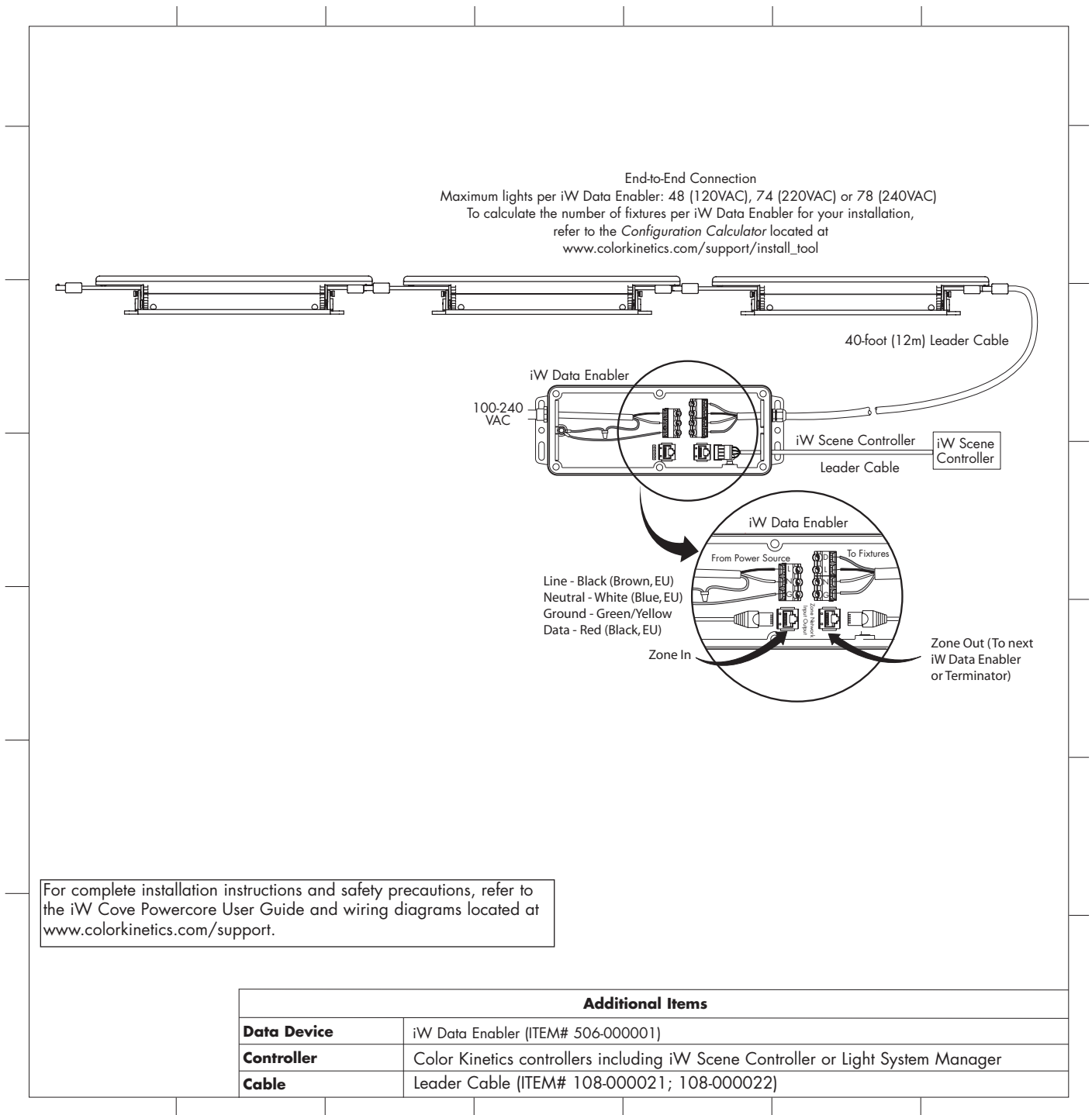

OPTIBIN®

There are inherent variations in the fabrication processes of all semiconductor materials. For LEDs, this variance results in differences in the color and intensity of light output as well as electrical characteristics. Due to these differences, LED manufacturers sort production into "bins," but insuring the availability of a single bin is very difficult. To minimize this issue and achieve optimal color consistency in its products, Color Kinetics has developed and uses a proprietary technology called Optibin. Optibin is an advanced production binning optimization process that minimizes the effects of LED variance for the best possible output uniformity in the final product. Color Kinetics Optibin technology gives the most consistent control of color and intensity from product to product.