



COLOR KINETICS INCORPORATED
10 MILK STREET, SUITE 1100
BOSTON, MA 02108
TEL 888 FULL RGB
TEL 617 423 9999
FAX 617 423 9998
INFO@COLORKINETICS.COM
WWW.COLORKINETICS.COM

ITEM# 103-000014-00
FOR USE UNDER U.S. PATENTS 6,016,038, 6,150,774, AND 6,340,868
OTHER PATENTS PENDING

©2003 Color Kinetics Incorporated. All rights reserved. Chromacore, Color Kinetics, the Color Kinetics logo, ColorBlast, ColorPlay, ColorScope, iColor, iColor Cove, iPlayer, QuickPlay, and Smartjuice are registered trademarks, and Chromasic, ColorBlaze, and ColorBurst are trademarks of Color Kinetics Incorporated.

All other brand or product names are trademarks or registered trademarks of their respective owners.
PUB-000070-00R01

Introduction

The Color Kinetics® ColorDial is a digital lighting controller that features eight pre-programmed effects, plus OFF, for Color Kinetics professional lighting. Effect selection and modification is easy with the rotary knob. Push to cycle through the effects and turn to vary the color or speed. ColorDial is packaged in an easy to use, wall-mount assembly.

Fig. 1

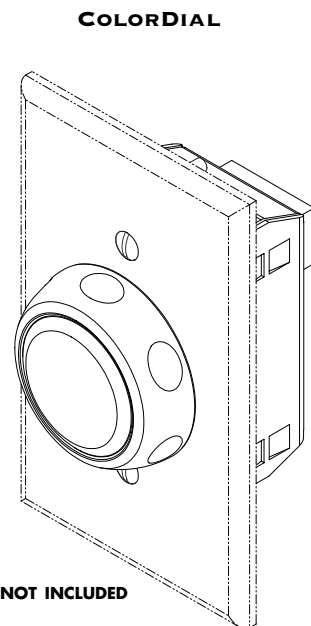

NOTE: FACE PLATE NOT INCLUDED

Included in this box:

- ColorDial Switch assembly
- Knob
- 2 - 6-32 pan head Phillips flat screws

Additional items you'll need:

- Single or multi gang wall box
- CAT 5 data cable, unshielded twisted pair, flying lead/RJ-45
- 18 AWG power cable with flying leads or 18 AWG power cable with BNC connector and coupling. Refer to the wiring diagrams to determine your installation requirement.
- Face Plate

Scope of This User Guide

The goal of this user guide is to explain in an easily understandable language the necessary steps to install the ColorDial and assure peak performance. Its intended use is for reference only, by persons who are fully qualified. This document should never be considered a substitute for any provisions of a regulation or state and/or local code.

Identification and Warnings of Safety Hazards

In accordance with ANSI Z535.4 the following system of identifying the severity of the hazards associated with the products is used:

"DANGER" Imminently hazardous situation which, if not avoided, will result in death or serious injury.

"WARNING" Potentially hazardous situation that, if not avoided, could result in death or serious injury.

"CAUTION" Potentially hazardous situation that, if not avoided, may result in minor or moderate injury or property damage.

WARNING: Ensure that main power supply is off before installing, wiring, or servicing the ColorDial. Failure to adhere to these instructions can result in death or serious injury.

WARNING: The ColorDial must be installed by a qualified professional in accordance with NEC and relevant local codes. Failure to comply can result in death, serious injury, or property damage.

WARNING: Do not attempt to install or use the ColorDial until you read and understand the installation instructions and safety labels. Failure to adhere to these instructions could result in serious injury or property damage.

CAUTION: Do not modify or alter the ColorDial. Doing so will void the warranty.

CAUTION: ColorDial has no user servicable parts. Do not open. Doing so will void the warranty.

NOTE: The instructions and precautions set forth in this user guide are not necessarily all-inclusive, all conceivable, or relevant to all applications as Color Kinetics cannot anticipate all conceivable or unique situations.

Owner/User Responsibilities

It is the responsibility of the contractor, installer, purchaser, owner, and user to install, maintain, and operate the ColorDial in such a manner as to comply with all state and local laws, ordinances, regulations, and the American National Standard Institute Safety Code.

Installation

The ColorDial shall be installed by a qualified electrician in accordance with NEC and relevant local codes for power supplies with Class 2 outputs.

Fig. 2

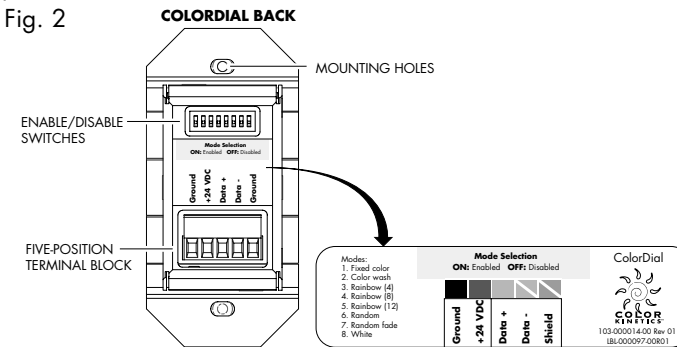

WARNING: Ensure that power is off before installing the ColorDial.

Wiring the ColorDial

1. Using the 18 AWG power cable, connect 24 VDC and ground from the Color Kinetics power supply to the screw terminal located on the back of the ColorDial.
2. Using the CAT 5 data cable, connect data from the Color Kinetics power/data supply to the screw terminal located on the back of the ColorDial.

Refer to the wiring diagrams on the back for your specific installation. Be sure to match the wire function to the terminal pin numbers.

NOTE: If you are installing the ColorDial more than 50 feet away from the Color Kinetics power/data supply, use a C-Series Power Supply with an 18 AWG power cable (flying lead/BNC with connector) to provide power.

Disable Effects

When you receive your ColorDial, eight light effects are pre-programmed and enabled. If you wish to limit the number of effects in the cycle, or if you know of effects that you will not use, you can disable them prior to physically installing the ColorDial into the wall box.

- To disable an effect, set its corresponding dip switch to OFF.

1. Fixed Color
2. Color Wash
3. Chasing Rainbow (4 lights wide)
4. Chasing Rainbow (8 lights wide)
5. Chasing Rainbow (12 lights wide)
6. Random Color
7. Random Fade
8. White



Note: Keep in mind that any effects you disable prior to installation can only be re-enabled by physically removing the ColorDial from the wall box and turning on the appropriate switch.

Mounting the ColorDial:

Now that you have wired the ColorDial, and disabled/enabled the desired effects, you are ready to mount it.

1. Using the screws provided, align the mounting holes to a one gang wall box, or a single area of a multi gang wall box, and attach.
2. Attach face plate.
3. Attach the knob by aligning the collar with the rotation shaft and press.

Your ColorDial is installed and ready to use.

Using the ColorDial

Using the ColorDial is as simple as pressing and turning.

Press the dial to cycle through the eight effect modes and OFF.

Turn the dial to vary the effects.

In Fixed Color mode, turning the dial changes the color. While in White mode, turning the dial changes the intensity. In all other modes, turning the dial adjusts the speed. ColorDial remembers your settings and recalls them each time you return to the effect.

Turn the dial clockwise to increase, and counter-clockwise to decrease, the speed. The first three revolutions of the dial varies the speed between approximately 1/2 second to about 2 minutes. After which, each click of the dial doubles the speed clock-wise or decreases by half counter-clockwise. When in this range, the lights snap to a new color with each click for visual confirmation of changes.

Note: In Chasing Rainbow, the speed of a single pass through the color spectrum ranges from 1/2 second to 5 hours. After the third rotation of the dial, the speed is reduced to the point that color changes are not immediately visible.

The ColorDial outputs data for light addresses 1 through 60. After the first 12 addresses, the data is repeated. For installations with more than 12 lights you can either sequentially address the lights past 12, up to 60, or repeat the addresses starting from 1. The effects will appear the same. Below is an example of light addressing with 24 lights.

Sequential Addressing



Repeat Addressing



A GLOSSARY OF TERMS

COLOR FACTORS: The impact of light source colors is determined by the combination of three factors: **hue**, **saturation**, and **luminance**. Hue indicates whether a color looks red, orange, yellow, green, blue, violet, etc. Saturation represents how pure a color is, and luminance (brightness) identifies how strong the color is.

FIXED COLOR: Fixed Color Effect is a static display of one color.

COLOR WASH: A Color Wash Effect produces a smooth transition in hue, progressing through the visible color spectrum: red, orange, yellow, green, blue, indigo, violet.

CYCLE DIRECTION: The sequence in which colors move through the spectrum: red, orange, yellow, green, blue, indigo, violet.

CHASING RAINBOW: Chasing Rainbow makes a smooth transition from color to color through the color spectrum. When applied to a group of lights the colors appear to follow each other from light to light.

RANDOM COLOR: Random Color Effect is an abrupt transition of 128 randomly generated colors at specified intervals. Colors jump from one hue to the next in spectrum increments of at least 25% so no two successive colors have similar values.

RANDOM FADE: Random Color Fade is a smooth transition of 128 randomly generated colors at specified intervals. Colors jump from one hue to the next in spectrum increments of at least 25% so no two successive colors have similar values.

SPEED: Determines the duration of an Effect. In Color Wash, Speed is defined as the amount of time which elapses between the initial display of the Starting Color in cycle one, and its next display which begins cycle two. In Cross Fade, Speed is defined as the amount of time which elapses between the initial display of the Starting Color to the display



